

Pulleys

# Articulated pulleys with support plates PA

---

Instruction manual

**EN**

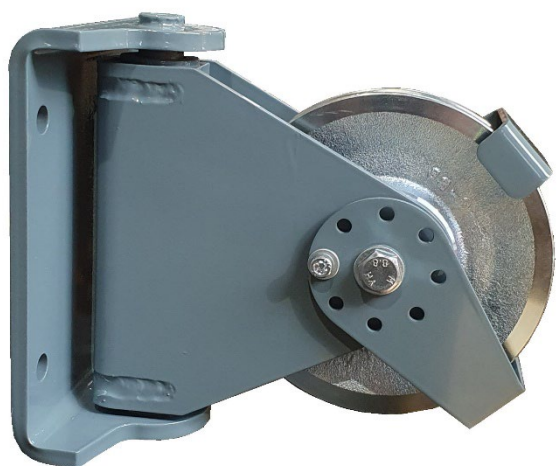

To ensure the constant improvement of its products,  
HUCHEZ reserves the right to change the equipment as described below and, in this case,  
to supply products which differ from the illustrations or specifications in this instruction manual.

## Contents

1. Conditions of use .....	p. 2
2. Safety instructions.....	p. 3
3. Warranty .....	p. 3
4. Reception of the equipment .....	p. 4
5. Compulsory regulatory inspections by the user .....	p. 4
6. Presentation of the machines.....	p. 5
7. Handling - Storage .....	p. 6
8. Assembly and start-up .....	p. 6
9. Servicing and maintenance .....	p. 8
10. Taking out of use .....	p. 8
11. Spare parts .....	p. 8
12. Declaration of conformity .....	p. 9
13. Appendices .....	p. 9

## 1 - Conditions of use

All users must read the set-up instructions carefully before using the product for the first time. These instructions should enable the user to familiarise themselves with the winch and use it to its full capacity. The set-up instructions contain important information about how to use the pulley safely and correctly. Compliance with these instructions helps to avoid danger, reduce repair costs, reduce stoppage time and improve the reliability and service life of the pulley. The instruction manual must always be available in the place where the pulley is being used. In addition to the set-up instructions and regulations concerning the prevention of accidents, the work safety and professional regulations in force in each country must also be respected.

This equipment is governed by European regulations and more specifically Directive 2006/42/EC on machinery.

These pulleys make it possible to change the direction of an appropriate steel cable. They have been designed to handle lifting and traction activities within the limit of the determined load capacity and with a safety factor of 4 (static against sudden failure).

- The capacity indicated on the pulley corresponds to the maximum capacity of use (MCU); in no event should this capacity be exceeded.
- **THIS PULLEY CAN UNDER NO CIRCUMSTANCES BE USED TO LIFT PEOPLE.**
- Do not begin moving the load until you have attached it correctly and checked that all personnel are outside the danger zone.
- Before use, the operator must always check that the machine, rope, hook, markings and moorings are in good working order.
- The pulleys can be used at ambient temperatures ranging from -10°C to +50°C. Please consult the manufacturer in the event of extreme conditions of use.
- HUCHEZ cannot accept any liability for the consequences resulting from the use or installation of equipment not provided for in the present instructions or for the consequences of removal, modification or replacement of original parts or components with parts or components from other sources without the written agreement of HUCHEZ.

**YOU MUST ALSO RESPECT THE REGULATIONS APPLICABLE IN YOUR COUNTRY.**

## 2 - Safety instructions

Before using the equipment, check that there are no causes of overloading such as: adhesion to the ground, suction, jamming, etc. of the load.

As the operator of the winch, you are responsible for your own safety and the safety of your colleagues in the work zone of the machine.

The operator must respect all the following safety information, without exception, concerning the handling and operation of the winch as well as the references to other sections of this instruction manual. Failure to comply with these instructions increases the level of risk.

- Only the people designated by the company are authorised to operate the pulley.
- Before using the pulley for the first time, familiarise yourself with its conditions of use. To this end, read the present instruction manual carefully and in its entirety and perform all the operations described herein one after the other.
- Inform your departmental manager or the safety officer of any malfunction so that the fault can be repaired immediately.
- Respect the directives of the industrial accident prevention organisations such as, in France, the Caisse Régionale d'Assurance Retraite et de la Santé au Travail (C.A.R.S.A.T.) and the Health and Safety Committee (HSC) of your company, if one exists.
- Scrupulously respect all information in the sections concerning the CONDITIONS OF USE (section §1) and the WORK ROPE (section §6.3).
- The operator(s) must have an unimpeded view of the load.
- Please ensure that the operator is qualified to operate the machine in the conditions provided for in this manual. This will ensure the safety of both people and the environment.
- Do not lift or transport loads when there are personnel inside the danger zone.
- Do not authorise the personnel to walk under a suspended load.
- Do not leave a load suspended or with the rope taut unsupervised.

In addition to the above instructions, we must warn you against all incorrect use or handling listed below. **It is dangerous and prohibited to:**

- **pull at an angle.**
- **swing the load.**
- **use ropes of a different diameter and texture to those specified in this instruction manual.**
- **use damaged ropes or ropes with splices.**
- **grab or touch a moving rope or a rotating drum.**
- **use hooks without a latch, which do not correspond to the loads indicated on the winch or which are in poor condition.**
- **insert objects into moving parts.**
- **work on loaded winches or when the rope is taut.**
- **use the winch rope as a towing chain.**
- **drum on the control box (overheating of the motor and electrical equipment).**
- **place hands or clothes, etc. in contact with moving parts, in particular the areas where the rope is wound in/out.**

### 3 - Warranty

Our pulleys are guaranteed for 1 year from the date of shipment (ex-works).  
The seller undertakes to repair any operating fault resulting from a fault in the design, execution, components or materials themselves.

The warranty does not cover wear and tear or damage resulting from a lack of regular or periodic maintenance. It does not cover damage resulting from a lack of supervision, incorrect handling or an incorrect use of the machines, in particular overloading, pulling at an angle, under or overvoltage or incorrect connection.

The warranty does not apply to any disassembly, modification or replacement of mechanical or electrical parts undertaken without our agreement or by a non-approved operator. The warranty only applies to the manufacturer's original spare parts. During the warranty period, the seller must replace or repair any parts recognised as faulty after inspection by the qualified and approved department, all free of charge.

The warranty excludes all other services or compensation.

Repairs undertaken within the scope of the warranty are, in principle, performed in the seller's workshops or the workshop of a representative approved by the manufacturer. When work is carried out on the equipment outside of their workshops, the seller must cover the labour costs related to the disassembly or reassembly of these parts if these operations are performed exclusively by their personnel or a representative approved by the manufacturer. The parts replaced become the property of the seller and must be returned to them at their own expense.

In the case of components with a particular relative importance not manufactured by the seller themselves and which bear the brand of a specialist manufacturer, the warranty, which may vary according to the manufacturer, is the same as that agreed by this manufacturer.

### 4 – Reception of the equipment

- Make a visual inspection of the packaging to ensure that it is in good condition.
- In the event of a problem, issue the usual reserves.
- Check that the pulley corresponds to your order.

### 5 – Compulsory regulatory inspections by the user

This equipment has been designed to be subjected to the following tests:

- Dynamic proof test at coefficient 1.1
- Static proof test at coefficient 1.25

Users are required to conform to the regulations in force in their own countries.

In the case of France:

Order of 1 March 2004 on the testing of lifting machines and accessories:

The amendments to the regulations regarding the use and testing of lifting machines and accessories, in force since 1 April 2005, impose new obligations on all users:

- Adaptation exam, which consists of checking that the lifting machine is suitable for the work the user intends to carry out as well as for the risks to which the workers are exposed and that the planned operations are compatible with the conditions for using the machine as defined by the manufacturer.
- Assembly and installation exam, which consists of making sure that the lifting machine is assembled and installed in a safe manner, in accordance with the manufacturer's instruction manual.
- Periodic general inspections, including an exam of the state of conservation and operating tests.
- Tests for starting or restarting service in the event of changing the operation site, changing the configuration or the conditions for use on the same site, following dismantlement and reassembly of the lifting machine, after any considerable replacement, repair or transformation affecting the core components of the lifting machine, following any accident caused by a failure in a core component of the lifting machine.

- Maintenance log (order of 2 March 2004, applicable since 1 April 2005) which must contain all the maintenance operations performed in accordance with the recommendations of the machine manufacturer as well as any other inspection, service, repair, replacement or modification operation conducted on the machine. Every operation must state the date of the work, the names of the persons and, where applicable, the companies that performed it, the nature of the operation and, in the case of a periodic operation, its periodicity. If the operations include replacing elements of the machine, the references of these elements must be specified. The English version of the maintenance booklet for our lifting winches can be downloaded from our website [www.huchez.fr/uk](http://www.huchez.fr/uk) under the heading "After sales services". A copy is however proposed in the annexes of this manual.
- The tests must be performed in strict observance of protocol. They aim to provide preventive maintenance, detecting any damage or faults that can create a risk.

## 6 – Presentation of the machines

Articulated pulleys (PA) with square hinge brackets are lifting and traction devices built in accordance with the regulations, rules and requirements in force.

### 6.1 Technical description

- Rigid steel structure.
- Steel bearing sheave
- Anti-overflow system for the cable.

### 6.2 Operation

Once the pulley has been installed, the cable may be run freely and diverted in all directions.

### 6.3 Available models

Ref.	Wire rope strength kg	Rope Ø mm	Ø ext. Sheaves (Sheave outer Ø) mm	Weight kg
PA6/7	1000	6 / 7	150	6.8
PA8/9	1600	8 / 9	200	13.2
PA10/11	2500	10 / 11	235	27
PA12/13	4000	12 / 13	297	34.1
PA15/16	5500	14 / 15 / 16	375	62.7

### 6.4 Dimensions and fastenings

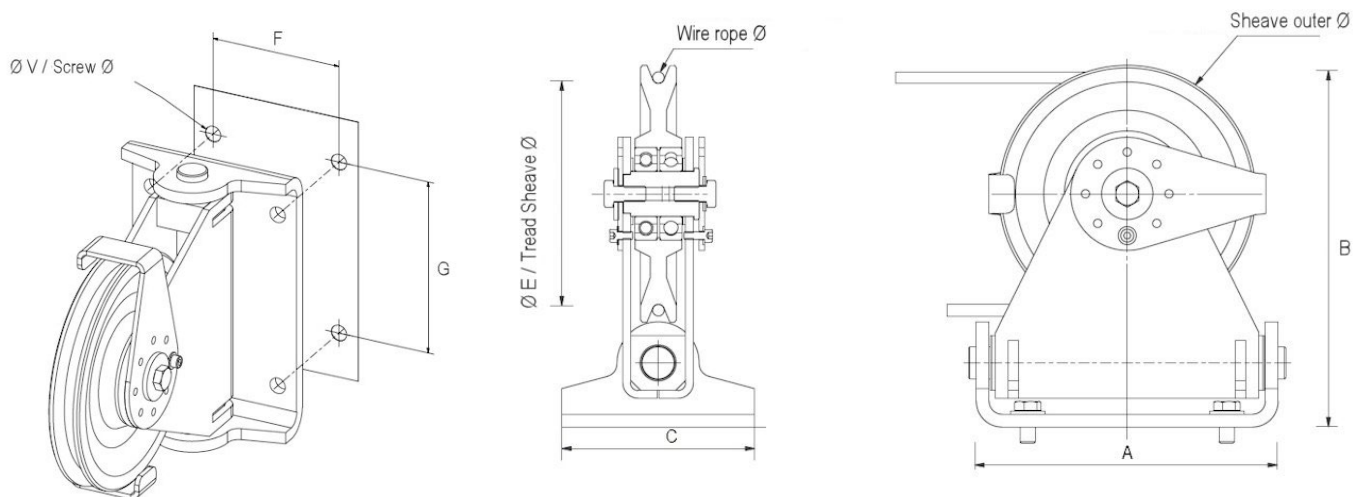

Ref.	A mm	B mm	C mm	ØE mm	ØV mm	F mm	G mm
PA6/7	198	224	125	133	12	95	110
PA8/9	247	281.5	150	172	14	115	155
PA10/11	286	331	180	200	18	130	180
PA12/13	348	397.5	200	250	18	140	235
PA15/16	434	492.5	240	320	23	170	300

## 6.5 Accessories

These pulleys can be delivered with winch and ropes.

## 7 – Handling - Storage

When stored, these pulleys must be protected from bad weather in a clean and dry place at a temperature between -10°C and +50°C.

## 8 – Assembly and start-up

### 8.1. Securing the pulley

The pulley must be installed and bolted on a clean and plane surface.

The flatness deviation between the 4 points of support must not exceed 1mm, in order to avoid undue strain on the device and ensure its longevity.

The support must be able to withstand the loads to which it is subjected. An unsuitable installation site may lead to serious accidents.

To assess the suitability of the place of installation and its resistance to loads, you must take into account any possible overloading, the weight of the winch itself and the weight of the options and/or accessories fitted to it, including all dynamic forces. The winch user is responsible for determining the place of installation. If in doubt with regard to the suitability of a place of installation, contact a civil engineer or a statics specialist.

Calculate and check that the attachment support has a resistance that exceeds the loads to be lifted or pulled.

Depending on models, the fixation must be performed using 4 screws of 8.8 class and diameter:

Ref.	Screw Size	Ø Opening mm
PA6/7	M10	12
PA8/9	M12	14
PA10/11	M16	18
PA12/13	M16	18
PA15/16	M22	23

### 8.2. Wire rope exits

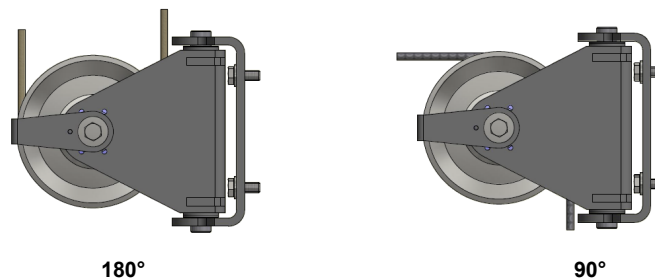

### 8.3. Set up

The service life of a pulley depends on its correct installation and set-up.

It is essential that you read this manual carefully before installing, using and servicing your machine.

Any use which contravenes our instructions may create hazards. In this case, the manufacturer cannot accept any liability.

Do not use this machine before having read and understood the instruction manual in its entirety

Always keep the manual close to the machine, available to the operator and the maintenance staff

Comply and ensure compliance with the safety rules.

It is also imperative to check the cable and the hook: for correct winding of the cable, a "return pulley – drum" distance of more than or equal to 20 times the length of the drum.

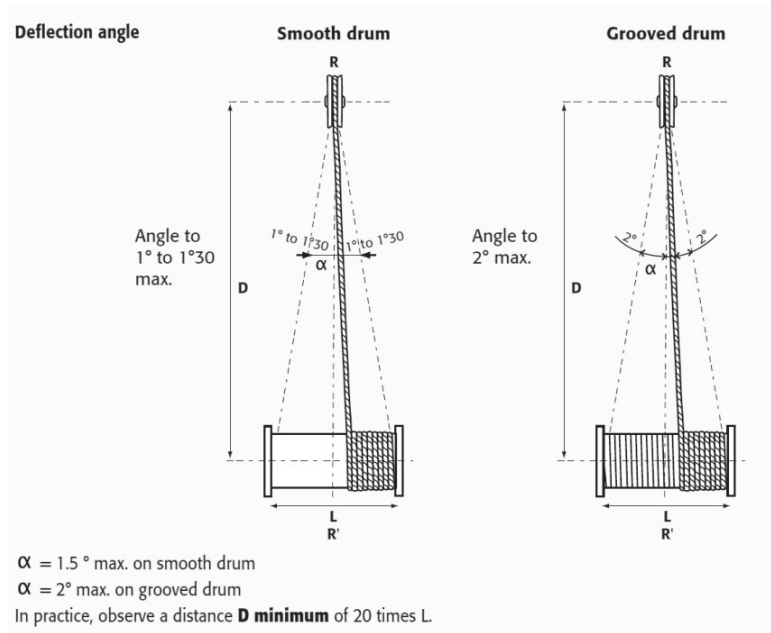

## 9 – Servicing and maintenance

Respect the following instructions, in particular if your pulley is used in a large number of different locations or in a particularly dirty and damp environment:

- Remove most of the dirt from the pulley.
- Always store the pulley in a dry, clean place.

**Servicing and maintenance operations on the rope must be carried out without any load on the winch.**

### Before starting up, check:

- Good condition of the bearings: the pulley must be properly fixed onto the axle, but must be able to turn freely.
- Fastening of the pulley.
- External appearance of the pulley, paying particular attention to wear and tear: the cable must not get stuck in the groove and must be able to be lifted slightly.

## 10 – Taking out of use

If the equipment is in a state of disrepair likely to give rise to risks, it must not be used and must be taken out of service:

- proceed to disassembly.
- to dispose of the material, take it to the appropriate collection centre.

## 11 – Spare parts

If during maintenance operations you notice that certain parts of your pulley need to be replaced, use HUCHEZ original parts only.

For all spare parts orders, please indicate the following specifications on your order

- ✓ The type and capacity of the pulley (indicated on the nameplate).
- ✓ The serial number and year of manufacture (indicated on the nameplate).
- ✓ The designation of the desired parts (exploded views).

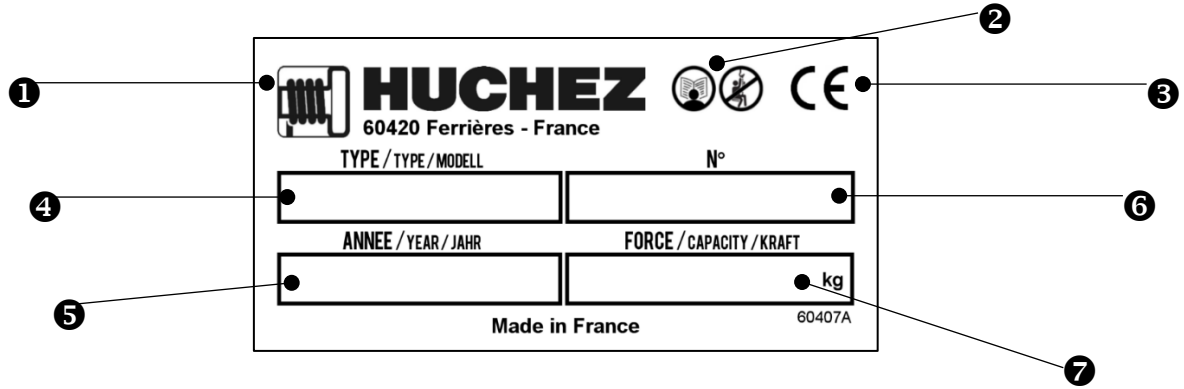

1	Manufacturer's logo and address
2	Warnings : Follow the instruction manual. Do not use to lift people.
3	CE mark
4	Reference
5	Year of manufacture
6	Serial number
7	Wire rope strength

**12 – Declaration of Conformity**

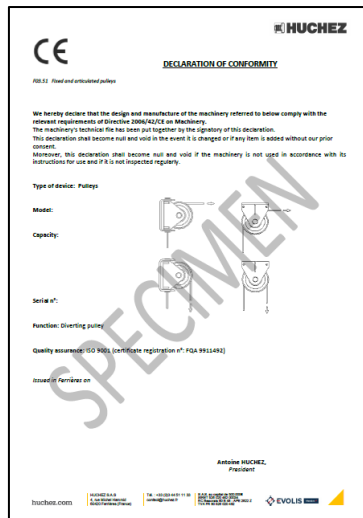

**13 – Appendices**

- **A** – Exploded views and spare parts lists
- **B** – Maintenance booklet

**A** Exploded views and spare parts lists

THE SERIAL NUMBER MUST BE SPECIFIED FOR ALL SPARE PART ORDERS.

PA6-7

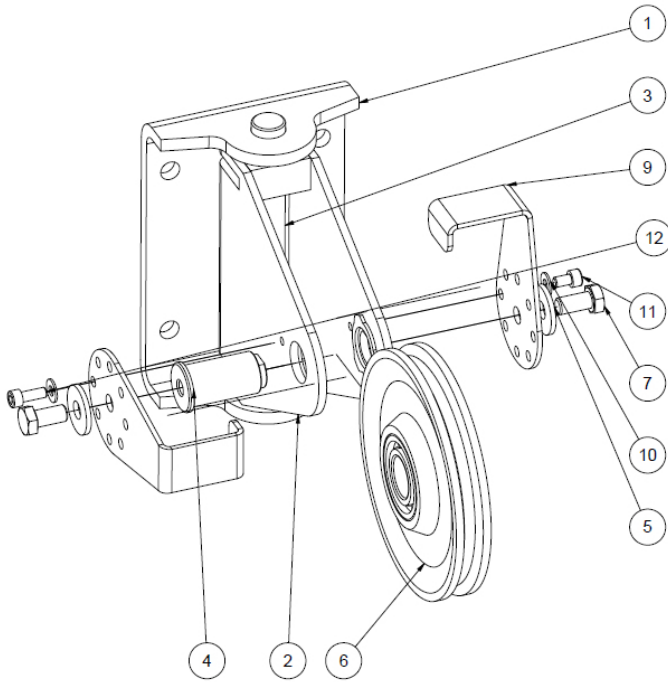

Key	Part N°	Quantity	Description
1	54771	1	PA Support
2	54772	1	Welded support assembly
3	54778	1	Rotation axle
4	54779	1	Pulley axle AP6-7
5	54767	2	Washer
6	REAS 503-150	1	Pulley Ø150 Series 503
7	13074	2	Screw TH ISO 4017 M 10-20
8	20039	2	Thrust washer 20x35x1
9	65504	2	Anti-overflow sheet PA6-7
10	13209-k	2	Washer M6
11	13426	1	Screw C HC M6x10
12	13131-k	1	Screw C HC M6x16

PA8-9

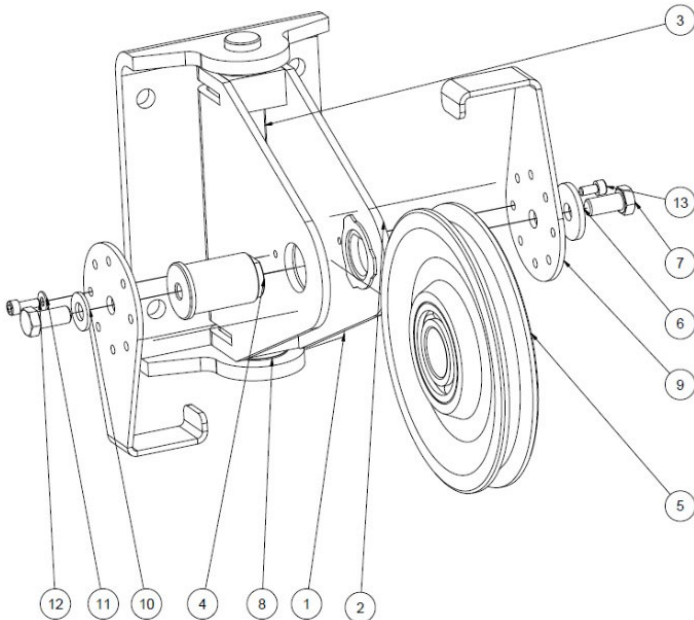

Key	Part N°	Quantity	Description
1	54719	1	PA Support
2	54726	1	Welded support assembly
3	54723	1	Rotation axle
4	54727	1	Pulley axle PA8-9
5	503200	1	Sheave 503 Ø200
6	54712	1	Washer
7	13082	4	Screw TH ISO 4017 M12-25
8	20044	2	Thrust washer AS2542
9	65505	2	Anti-overflow sheet PA8-9
10	13212-k	1	Washer M12
11	13209-k	2	Washer M6
12	13131-k	1	Screw C HC M6x16
13	13652	1	Screw C HC M6x12

THE SERIAL NUMBER MUST BE SPECIFIED FOR ALL SPARE PART ORDERS.

PA10-11

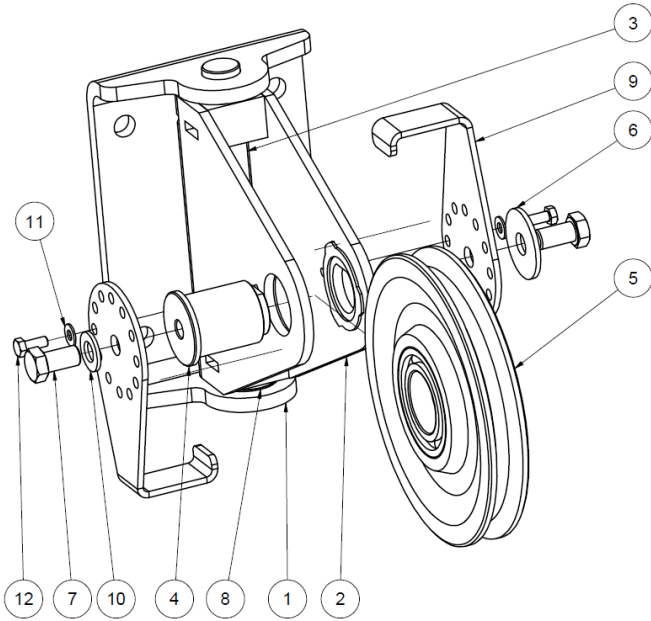

Key	Part N°	Quantity	Description
1	67473	1	PA Support
2	67474	1	Welded clevis PA
3	67478	1	Rotation axle
4	67479	1	Pulley axle PA 10-11
5	503235	1	Pulley sheaves 10-11
6	67489	1	Washer
7	13625	2	Screw H M16 x 30
8	20144	2	Thrust washer AS3047
9	67480	2	Anti-overflow sheet PA10-11
10	13214-k	1	Washer M16
11	13210-k	2	Washer M8
12	13065-k	2	Screw H M8 x 20

PA12-13

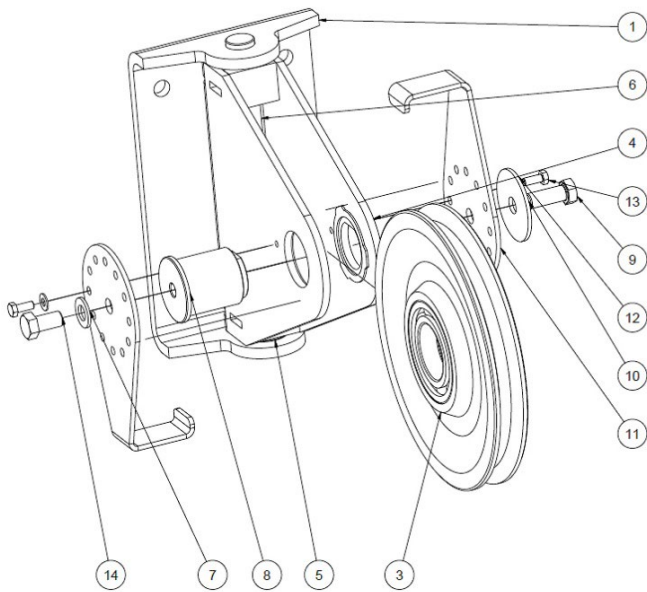

Key	Part N°	Quantity	Description
1	54731	1	PA Support
3	REAS 503-297	1	Pulley sheaves 503 Ø297
4	54737	1	Welded support assembly
5	AS3047	2	Washer FAG 30x47x1
6	54738	1	Rotation axle
7	13214	3	Washer MU 16
8	54739	1	Pulley axle PA12-13
9	Vis HM 16x40	1	Screw H M 16x40
10	54577	1	Washer
11	64462-02	2	Anti-overflow sheet
12	13210-k	2	Washer M8
13	13065-k	2	Screw H M8x20
14	13625	1	Screw H M16x30

PA15-16

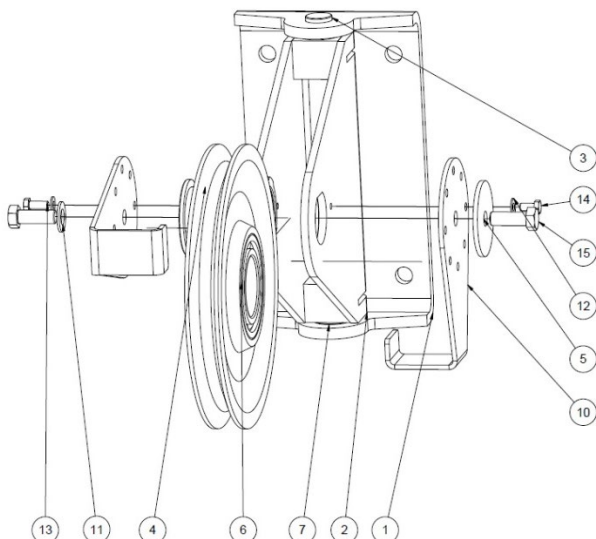

Key	Part N°	Quantity	Description
1	54794	1	PA Support
2	54800	1	Welded support assembly
3	54801	1	Rotation axle
4	54802	1	Pulley axle PA15-16
5	54790	1	Washer
6	REAS 503-375	1	Pulley sheaves 503 Ø375
7	AS3552	2	Washer FAG 35x52x1
10	65507	2	Anti-overflow sheet PA15-16
11	13216-k	1	Washer M20
12	13306	2	Washer M10
13	13075	1	Screw H M10x25
14	13074-k	1	Screw H M10x20
15	13412	2	Screw H M18x50



The English version of the maintenance booklet for our lifting winches can be downloaded from our website [www.huchez.fr/uk](http://www.huchez.fr/uk) under the heading "After sales services".

Date	Person in charge Company	Name	Nature of the operation	References of replaced parts	Frequency if appropriate	Signature

Huchez© 2012

